



Basement Finish Permit Information

Based upon the 2009 International Residential Code

OWNER'S NAME _____ PERMIT # _____

GENERAL CONTRACTOR _____

PROJECT ADDRESS _____

I hereby acknowledge the receipt of the attached handout. I understand that inspections are required prior to concealing any work and are the responsibility of both the contractor and the homeowner. I understand that any changes to the plans will require additional review and written approval from the Building Division prior to proceeding with construction.

Owner signature: _____ Date: _____

Contractor Signature: _____ Date: _____

This list is an integral part of your approved plans. All items contained on this list are minimum code requirements and must be complied with if your construction is to receive inspection approvals. Every effort has been made to note all necessary corrections during our plan review process. However, ultimately, it is the responsibility of the builder to perform the construction according to minimum code requirements, regardless of whether or not the items are noted on this list. If you have any questions whatsoever, please contact the building division at 303-438-6370 before proceeding.

This set of approved plans (stamped "reviewed for code compliance," dated and initialed) must be available to the building inspector on the site when inspections are made. Failure to have these approved plans on the job site will result in:

- * no inspection being performed,
- * no inspection approval,
- * no approval to proceed with the construction, and
- * payment of a \$50.00 re-inspection fee at the building division before the inspection will be rescheduled (BMC 15-03-100 Table 1A).

LICENSING REQUIREMENTS FOR PLUMBING AND ELECTRICAL WORK.

Per Colorado law (CRS 12-58-101 et seq & 12-23-101 et seq, respectively), persons performing plumbing or electrical work for hire must be licensed by the State Plumbing or Electrical board, respectively, and must be working under the supervision of persons licensed by the state to operate a plumbing or electrical business. For plumbing work, this means that the individual must not only be licensed by the state as a plumber, but must also either hold a Master Plumber's license or be working under the direct supervision of a Master Plumber. For electrical work, the person doing the work must not only be licensed, but must also either hold a Master Electrician's license and an Electrical Contractor's license or be working under the direct supervision of an individual licensed as such. The only applicable exception to these laws is that individuals may perform electrical or plumbing work within their own home. (See CRS 12-58-113(2) and 12-23-111(2), for details).

Basement Finish - Important Code Requirements

General/Building Code Provisions

- B-1 **Fire Blocking** and draft stopping shall be installed in combustible construction per IRC Section R602.8./R302.11 See attached sheets for details.
- B-2 **Notches** in wall studs shall not exceed 25% of the stud depth. **Holes drilled in studs** shall not exceed 40% of stud depth with minimum $\frac{5}{8}$ " from hole to edge. Wires or pipes through holes in studs less than $1\frac{1}{2}$ " from nearest edge of stud shall be protected by a 0.0625" thick shield plate. IRC Sections R602.6, P2603.2.1, M1308.1, and NEC 300.4
- B-3 Due to potential **floor heaving**, non-bearing walls on slab-on-grade basement floors shall be built to accommodate floor movement per the site specific soils report.
- B-4 Bathtub and **shower enclosures** shall have cement, fiber-cement, or glass-mat gypsum backer applied to the wall studs under wall finishes to a point not less than 72" above the drain inlet per IRC Section R702.4. Water resistant gypsum board may be used in other areas, except where there will be direct exposure to water, in areas subject to continuous high humidity, or on ceilings where framing exceeds 12" on center.
- B-5 All exterior walls, whether above or below grade, shall be **insulated** with an approved insulating material that has a minimum "R" value of 13 if installed in stud cavities, or minimum R-10 if installed as continuous insulation. Please note that paper faced batt insulation shall not be installed without an outer covering, (i.e. drywall, paneling) – see warning label on paper facing. IRC Section R316.
- B-6 Every sleeping room (or basement without sleeping room) shall have one exterior door or **escape and rescue window** with a minimum of 5.7 sq. ft. of net clear opening. The minimum height of this clear opening shall be at least 24". The minimum width of the clear opening shall be at least 20". Note that a window with both the minimum width and the minimum height **cannot** be used to achieve the 5.7 square foot net clear opening required. Sill height shall not be greater than 44" above the finished floor. IRC Section R310.1. If a new or enlarged window opening is proposed in an existing foundation wall, an engineer's letter shall be submitted showing structural reinforcement details for the new or enlarged opening. Special inspection for the foundation modification may be required by an approved third party inspector or the design engineer.
- B-7 **Egress window wells** are required for emergency escape and rescue windows below grade in all sleeping rooms or areas. Egress window wells shall have a minimum accessible net clear opening of 9 sq. ft. with the window in the fully open position. Provide a minimum dimension of 36" in both directions. Window wells with a vertical depth of more than 44" shall be equipped with an approved, permanently affixed ladder or stairs that are accessible with the window in the fully open position. Existing window wells will need to meet these specific requirements. IRC Section R310.2.1. See also item B6 above. IRC Section R310.2.
- B-8 Habitable space shall have a **ceiling height** of not less than 7' except as otherwise permitted in IRC Section R305. Exceptions could be accepted in accordance with BMC 15-03-060 (J).
- B-9 **Stairway** minimum **headroom height** requirement is 6' 8". IRC Section R311.7.2
- B-10 For enclosed usable **space under stairs**, provide $\frac{1}{2}$ " gypsum board to the underside of walls and soffit. IRC Section R302.7. Fire stop stairs at stringers. IRC Section R602.8/R302.11.

- B-11 **Changing floor finishes on the stairs or landings** may create a violation for the riser heights in accordance with IRC Section R311.7.4.
- The maximum riser height shall be 7¾ inches measured vertically between the leading edges of adjacent treads (8 inches for homes built before December 2003).
 - Minimum tread depth shall be 10 inches measured horizontally between the vertical planes of the foremost projection of adjacent treads and at a right angle to the tread's leading edge (9 inches for homes built before December 2003).
 - The greatest riser height or the greatest tread depth within any flight of stairs shall not exceed the smallest by more than 3/8 inch.
 - A ¾ to 1½ inch nosing is required on tread depths smaller than 11 inches in homes built after December 2003. The greatest nosing projection shall not exceed the smallest nosing projection by more than 3/8 inch between two stories, including the nosing at the level of floors and landings.
- B-12 **Stair handrails and guards** shall be placed 34" minimum to 38" maximum above a line connecting the leading edges of the treads. Handrails shall be grippable with cross-sectional dimensions of 1¼ " to 2". There shall be 1½" minimum clear space between handrail and the wall. Guards shall be located along open-sided walking surfaces, including stairs, ramps and landings, that are located more than 30 inches measured vertically to the floor below. Openings in required guards on the open sides of stairs shall not allow passage of a sphere 4⅜ inches in diameter (4 inches at all other guards). The triangular openings at the open side of a stair (formed by the riser, tread and bottom rail of a guard) shall not allow passage of a sphere 6 inches in diameter. IRC Sections R311.7.7; R312.
- B-13 **Smoke alarms** shall be installed in each sleeping room and at a point centrally located in the corridor or area giving access to each separate sleeping area. When the dwelling has more than one story and in dwellings with basements, an alarm shall be installed on each story and in the basement. In dwellings with split levels and without an intervening door between the adjacent levels, a smoke alarm installed on the upper level shall suffice for the adjacent lower level provided that the lower level is less than one full story below the upper level. Alarms shall be audible in all sleeping areas of the dwelling unit. All new alarms shall be hard wired into 120 volt system and interconnected. When a basement finish building permit is issued, the existing dwelling shall have smoke alarms installed as required for new dwellings. When adding smoke alarms to existing portions of the house, they shall be hard wired wherever there is access for wiring, and may be battery operated elsewhere. IRC Section R314. Please note that all new alarms serving sleeping rooms shall be protected with a combination-type arc fault circuit interrupter (see comment E6).
- B-14 **Carbon monoxide alarms** shall be installed in existing dwelling units whenever they are altered. Carbon monoxide (CO) alarms shall be installed within 15 feet of the entry to all new and existing sleeping rooms in compliance with the manufacturer's written installation instructions. These devices shall produce a distinct, audible alarm and may be combined with a smoke detector if the combined device produces an alarm, or an alarm and voice signal that clearly differentiates between the two hazards. All CO alarms shall be listed by an approved, nationally recognized, independent product-safety testing and certification laboratory. Carbon monoxide alarms shall be powered by one of the following methods: fully battery powered, plug-connected into a dwelling's unswitched electrical outlet and include a battery backup, wired into a dwelling's electrical system and include a battery back-up, or connected to an electrical system via an electrical panel.
- B-15 All habitable rooms shall be provided with **heating facilities** capable of maintaining a room temperature of 68 degrees Fahrenheit at 3 feet above the floor and 2 feet from exterior walls. New ducts shall not be tied into existing 6" or 8" ducts for other floors. IRC Section R303.8. Adequate return air shall be provided in accordance with IRC Section M1602. This may be accomplished by transfer grills between rooms, undercutting doors, or a direct connection to the return air plenum. Return air openings shall be approximately the same size as the supply openings into the room. Tightly sealed stud cavities may be used for transfer of return air only.

- B-16 All habitable rooms shall be provided with **natural light and ventilation** by means of openable windows or doors. Habitable rooms are permitted to be without windows only if they are provided with adequate artificial light and mechanical ventilation capable of producing 0.35 air changes per hour per IRC Section R303.
- B-17 **Safety glazing** is required per IRC Section 308.4, specifically as follows:
1. Within a 24" arc of either vertical edge of a door (except in a wall perpendicular to the door other than the wall toward which the door swings).
 2. In stairway enclosures.
 3. In bathtub & shower enclosures.

Electrical Code Provisions

- E-1 All 125 volt, 15 and 20 amp receptacles installed in a residence shall be listed **tamper-resistant receptacles**. No exceptions for receptacles on ceilings, above counters or behind appliances. 2011 NEC 406.12
- E-2 At least one wall switch-controlled **light fixture** or outlet shall be installed in every habitable room, in bathrooms, hallways, and stairways. No usable wall space shall be more than 6' from a **receptacle outlet**, and a receptacle outlet is required at all counters 12" wide or more, and on any usable wall over 2'.
- E-3 Incandescent **luminaires** installed in **clothes closets** shall be enclosed and located not less than 12" from the face of the shelf. Fluorescent fixtures shall be enclosed and located not less than 6" from the face of the shelf.
- E-4 **Bathrooms** shall be supplied by at least one 20-amp branch circuit that serves only bathroom receptacles. This circuit may serve the lights, fan, and outlets within the bathroom if the circuit serves only the one bathroom. There shall be a **GFCI protected receptacle outlet** adjacent to and within 36" of the edge of each sink.
- E-5 Receptacle outlets shall be GFCI protected when installed in crawl spaces, in unfinished portions of the basement, to serve kitchen countertops, and within 6 feet of the outside edge of any sink not in a kitchen. **All GFCI protected receptacle outlets** shall be installed in a readily accessible location.
- E-6 Follow manufacturer's installation requirements for installing romex (nonmetallic sheathed cable), especially into **recessed can lights**.
- E-7 The front edge of **electrical boxes** shall be set back not more than ¼ inch from the finished surface of the wall or ceiling. Plaster, drywall, or plasterboard that is broken or incomplete around electrical boxes using a flush cover or faceplate shall be repaired so that there will be no gaps or open spaces greater than 1/8 inch.
- E-8 Boxes for **lighting outlets in ceilings** shall be designed for the purpose and shall be required to support a luminaire weighing a minimum of 50 pounds. Boxes for **lighting outlets in a wall** shall be designed for the purpose and shall be marked to indicate the maximum weight of the luminaire to be supported. 2011 NEC 314.27.
- E-9 All 120 volt, 15 or 20 amp branch circuits supplying outlets in family rooms, dining rooms, living rooms, parlors, libraries, dens, bedrooms, sunrooms, recreation rooms, closets, hallways or similar rooms shall be protected by a listed **combination type arc-fault circuit interrupter (AFCI)**. This will include new smoke alarms installed within existing bedrooms/sleeping areas. AFCI protection is not required for kitchens, bathrooms, garages and unfinished basements. Please note that many AFCI circuit breakers will not work with a shared neutral and wiring changes may be required. 2011 NEC 210.12.

- E-10 As a rule of thumb, you will need at least one 15 amp circuit for each 600 square feet of finished floor area or one 20 amp circuit for each 800 square feet of finished floor area. Twenty amp circuits shall be wired with minimum 12 AWG; fifteen amp circuits shall be wired with minimum 14 AWG. All breakers in panels must be marked clearly for the loads served. Spare breakers must also be marked. 2011 NEC 408.4.
- E-11 At least 50% of all light fixtures shall have approved High Efficacy lamps, which are compact fluorescent lamps, T-8 or smaller diameter linear fluorescent lamps or lamps with a minimum efficacy of:
1. 60 lumens per watt for lamps over 40 watts.
 2. 50 lumens per watt for lamps over 15 watts to 40 watts.
 3. 40 lumens per watt for lamps 15 watts or less.

Mechanical Code Provisions

- M-1 Provide smooth, rigid vent to the outside assembled with no screws for **clothes dryer** exhaust duct. The total combined length, horizontal and vertical, shall not exceed 25' – minus 2.5' for each 45 degree fitting and minus 5' for each 90 degree fitting. The maximum length does not include the transition duct. IRC Section M1502. Exhaust terminations shall be in accordance with manufacturer's installation instructions and shall be no closer than 3' to openings into building. Flexible non-metallic dryer vent shall not be concealed within walls or ceilings.
- M-2 Provide an **exhaust fan** connected to the exterior and capable of minimum 50 cfm for intermittent ventilation in all bathrooms without operable windows. IRC Section R303.3. . Ducts shall be constructed in accordance with IRC Section M1601.1.1.
- M-3 Provide minimum 1" clearance from **Type "B" gas vents** to combustible material; maintain 6" clearance from single wall vent connectors to combustible material per IRC Table G2427.7.7.
- M-4 No **gas water heater or furnace** shall be installed in any room used or designed to be used for sleeping purposes, bathrooms, clothes closets, or other confined space opening into any bedroom or bathroom unless the appliances are in a sealed enclosure so that combustion air will not be taken from the living space. IRC Sections M2005.2 and G2406.2.
- M-5 Provide minimum 3" working clearance along the top, sides, and back of the furnace, with the alcove or space a minimum of 12 inches wider than the furnace. There shall be 6" minimum clear space along the front combustion chamber side. Maintain 30" x 30" **level service space** in front or on the service side of all appliances. IRC Section M1305.1.
- M-6 Doors to **gas appliance enclosures** shall be a minimum of 24" in width but not less than that required for removal of the appliance. Door location shall be such that removal of any equipment does not require moving any other equipment. IRC Section M1305.1.2.
- M-7 Fuel burning equipment shall be assured a sufficient supply of **combustion air**. This provision does not apply to direct vent appliances, appliances listed as having separated combustion systems, enclosed furnaces, listed cooking appliances, refrigerators and domestic clothes dryers. IRC Chapter 24. The simplest method to comply is to provide one permanent opening within 12 inches of the top of the enclosure ducted directly to the exterior with a minimum area of not less than 1 square inch for each 3,000 Btu/h of the total input rating of the appliances in the enclosure. Outside combustion air openings shall be covered with corrosion resistant screening having ¼ inch minimum openings and ½ inch maximum openings per IRC Section R303.5. Refer to IRC Section G2407.6 for other sizing criteria and configuration options.

Plumbing Code Provisions

- P-1 The **water closet** stool shall be located in a space not less than 30" in width, with a minimum of 15 inches on each side of the centerline of stool, and shall have a clear space in front of the stool of not less than 21". IRC Section R307.1 and P2705.1.
- P-2 Tank type water closets shall have a flush with not more than 1.6 gallons of water; shower heads shall have **flow capacity** of not more than 3 gpm; kitchen sinks shall have flow capacity of not more than 2.5 gpm; and lavatory faucets shall have a flow capacity of not more than 2 gpm in accordance with IRC Section. P2903.2.
- P-3 Showers and tub/shower combinations shall be provided with individual control valves of the pressure balance or the thermostatic **mixing valve** type per IRC Section P2708.3. The high limit stop of the mixing valve shall be set to limit water temperature to not more than 120°F.
- P-4 Every **water heater** installation shall be accessible for inspection, repair, or replacement. The appliance space shall be provided with an opening or doorway of sufficient size to remove the water heater. IRC Section M1305.1.
- P-5 Provide access to all **cleanouts** per IRC Section P3005.2.5. Cleanout plugs shall not be concealed by permanent finishing material.
- P-6 Addition of sleeping rooms may require a larger **septic system**. Contact Broomfield Environmental Health, Stephen Stillwell, 720-887-2293.

REQUIRED INSPECTIONS

The permit holder shall obtain the inspections listed below and on the inspection record card. If you are unsure which inspections are required, please call the Building Division (303-438-6370). An inspection checklist is available from the building division counter or website: <http://www.broomfield.org/building>.

1. **Underground Plumbing/Shower Base:** This inspection is required when it is necessary or desirable to pour concrete over or otherwise cover part of the plumbing installation before the entire rough-in is completed. This inspection can be combined with the rough plumbing inspection if all parts of the system are still open and visible to the inspector at that time. A pressure test using either air or water, as outlined in Section 2503 of the IRC, is required: for a shower base - plug the drain and then fill the base and pencil mark the water level; for a tub - fill the tub with water so the inspector can visually check the shoe and trap for leaks. For structural wood floors, fixtures shall be installed and air or water tested; access shall be provided through the floor close by where the inspector can check for leaks.
2. **Rough Electrical, Framing, Plumbing, and Mechanical** (Combination Inspection): These are done as a combination rough inspection and shall be called in as one inspection when all rough-in work is complete and ready for inspection. All special inspection reports (such as those required for new or enlarged foundation wall openings) shall be submitted prior to calling for rough inspections.

The electrical rough-in must be complete: all circuits made up; boxes and plaster rings installed; electrical panel set; neutral and ground wires made up; and all grounding complete. The basement shall be ready for drywall with the exception of insulation. **Do not install any devices (plugs or switches) for rough inspection. All ground wires in boxes must be tied together with pigtail with approved wire nut.** Approved crimp sleeves may be used if proper size and proper tool used.

All **air or water pressure tests** required by Sections G2417.4 and P2503 of the IRC shall be ready at rough plumbing inspection for water supply, waste and vent, and gas piping. Water supply piping shall be tested by air pressure not less than 50 psi, or by water under pressure not less than the working pressure of the system. Waste and vent piping shall be tested by air pressure of not less than 5 psi or by water filled to not less than 10 feet above the highest fitting being tested. Gas pipe shall be tested by air pressure of not less than 10 psi

All **ductwork** shall be in place and adequately supported. All joints and seams shall be made substantially airtight by means of listed tapes, gaskets, mastics or other approved means. Generic "duct tape" is **not** listed for this purpose. IRC Section M1601.3.

All **framing** shall be in place, including required fireblocking at all interconnections between concealed vertical and horizontal spaces, horizontally at intervals not exceeding 10 feet, and at openings around vents, pipes, wiring, and ducts at ceiling level. Wires or pipes through holes drilled closer than 1¹/₂ inches from the face of framing members shall be protected by 16 gauge steel shield plates.
3. **Insulation:** This inspection shall be called to check for the required insulation installation; the R-value and the flame spread and smoke developed rating for any facings not in substantial contact with the back side of drywall.
4. **Tile Backer and Drywall:** The cementitious tile backer board in the tub/shower area and the drywall in the concealed usable space under the stairs will be checked.
5. **Above Ceiling:** This inspection is required where suspended grid type ceilings are to be installed and shall be requested after all work above the grid ceiling is completed, the grid is installed, all light fixtures are set, all grills, registers, and connecting ductwork are completed, but before any tile has been installed.
6. **Final Building, Electrical, Plumbing, and Mechanical:** Final inspections shall be requested when all work is completed and the space is ready for occupancy. Final building, electrical, plumbing, and mechanical will be done as a combination inspection and shall be called in as one inspection. No furniture or other use of the space is permitted until all inspections have been approved.



Building Guide

Colorado Chapter of the International Code Council

Single Family Residential Basement Finish

How to Use this Guide

Provide two sets of plans, drawn to scale and complete the following (*hint: use graph paper with 1/4" squares. Example: 1/4" = 1'*):

1. Review this Building Guide
2. Provide 2 Floor Plans
3. Fill out a Building Permit Application

The majority of permit applications are processed with little delay. The submitted documents will help determine if the project is in compliance with building safety codes, zoning ordinances and other applicable laws.

Smoke alarms and carbon monoxide alarms are required.

The Colorado Chapter of the International Code Council is a professional organization seeking to promote the public health, safety and welfare to building construction. We appreciate your feedback and suggestions. To obtain a master copy of this building guide, please write to the Colorado Chapter of the International Code Council, P.O. Box 961, Arvada, CO 80001.
<http://www.coloradochaptericc.org>

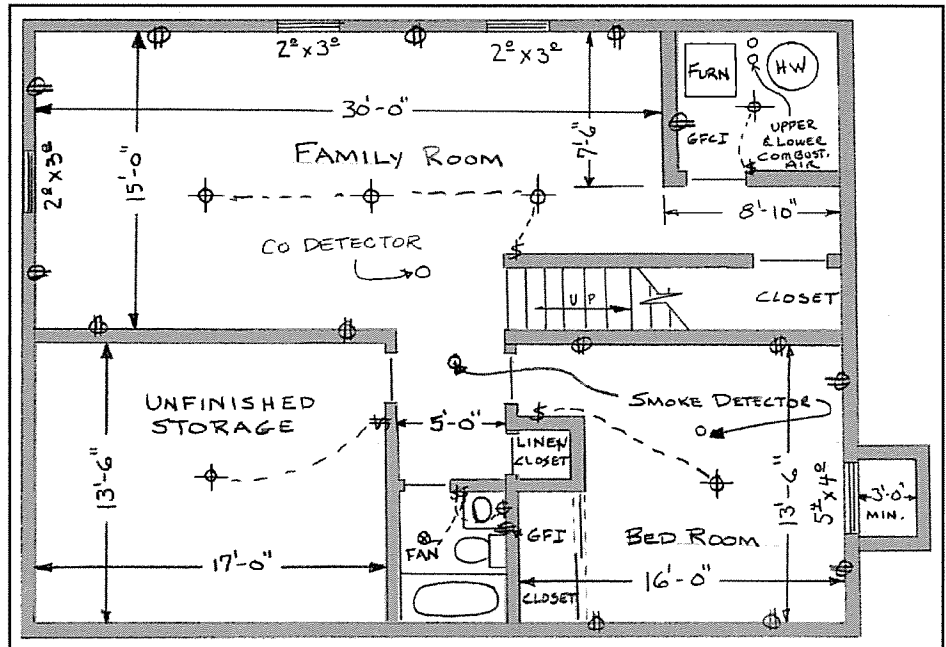

This handout was developed by the Colorado Chapter of the International Code Council as a basic plan submittal under the 2009 International Residential Code. It is not intended to cover all circumstances. Check with your Department of Building Safety for additional requirements.



Building Division

Community Development PHONE: 303.438.6370
1 DesCombes Drive FAX: 303.438.6207
Broomfield, CO 80020 www.broomfield.org

Single Family Residential Basement Finish

Directions

1. Submit two complete sets of required information.
2. Draw a floor plan with dimensions drawn to scale, showing the layout of the entire basement. Label the use for all of the rooms.
3. Show electrical outlets, smoke detectors, carbon monoxide alarms, lighting, fans, plumbing modifications, cleanouts, furnace, and water heater.
4. List window sizes and types, identify emergency escape and rescue windows, and egress window wells with ladder and clear dimensions of window well.
5. Identify modifications to the existing structure such as posts, beams and floor joists.
6. Indicate height of dropped ceiling areas less than 7 feet.
7. A shower or tub equipped with a showerhead shall have a minimum ceiling height of 6' 8" above a minimum area 30" by 30" at the showerhead. See Exception 2, P2708.1.
8. Show clearance around the tub and fixtures.
9. Show insulation values

Basement Finish Requirements

1. Ceiling Heights:

If the finished ceiling will be less than 7', please consult your Building Department.

2. Emergency Escapes:

All basements and sleeping rooms must have an emergency escape window or exterior door. Emergency escape windows with a sill height below grade must be provided with an emergency escape window well and ladder. (For emergency escape window and window well requirements, see page 3.)

3. Smoke Alarms:

Smoke alarms are required in all basements. If the finished basement contains a sleeping room, a smoke alarm must be installed on the ceiling or wall in the sleeping room and in the hallway or area immediately outside of the sleeping room. Smoke alarms added to satisfy the above requirements must be hard-wired with battery backup, and interconnected with existing smoke alarms. Smoke alarms are required to be hardwired and interconnected in new and existing bedrooms, halls and on each level unless removal of interior wall or ceiling finishes would be required. In this case, battery operated devices are acceptable.

4. Carbon Monoxide Alarms:

Carbon Monoxide alarms are required on each floor with bedrooms. They are recommended to be located no farther than 15 ft. from any bedroom entrance. Do not install within 15 ft. of a fuel burning appliances. Follow manufacture's recommendations for location testing and replacement.

5. Fuel Burning Appliances:

Furnaces and water heaters cannot be located in a bedroom or bathroom unless appliances are installed in a dedicated enclosure in which all combustion air is taken directly from outdoors, and a weather stripped solid door equipped with an approved self closing device is installed. If the furnace and water heater are being enclosed, adequate combustion air must be provided for these appliances to operate properly. For maintenance purposes, a minimum of 30 inches clear working space must be provided in front of furnaces and water heaters. Maintenance or removal of each appliance must be possible without removing the other or disturbing walls, piping, valves, wiring and junction boxes.

6. Floated Walls:

In areas subject to floor heaving, non-bearing walls on slab-on-grade basement floors shall be built to accommodate floor movement as recommended by the site specific soils report; if no report exists, provide not less than 1-1/2 inches. A detail of a typical floated wall is included on Page 3 of this hand-out.

Fireblocking must be installed in concealed spaces of wood-furred walls at the ceiling level, at 10-foot intervals along the length of the wall and at all interconnections of concealed vertical and horizontal spaces such as intersection of stud walls and soffits or dropped ceilings. A detail of typical fireblocking is included on the following page of this handout. Fireblocks may be constructed of 1-1/2 inch lumber, 3/4 inch plywood or particle board, 1/2 inch gypsum board or fiberglass insulation 16 inches minimum in height, securely fastened.

8. Insulation:

Check with your Building Department for insulation requirements.

9. Space Under Stairs:

If access to the area or space under the basement stairs is provided for storage or other uses, the walls and ceiling of this enclosed space must be protected on the inside with 1/2" gypsum board.

10. Bathrooms:

Toilets must be provided with a minimum of 21 inches in front of the toilet and 15 inches from the center of the toilet and any sidewall or other obstruction. Showers shall have a minimum inside dimension of 900 square inches, capable of encompassing a 30 inch circle and be finished 72 inches above the floor with non-absorbent materials. See Exception 2, P2708.1.

A ventilation fan is required in toilet rooms and bathrooms with unopenable windows. The fan must be vented to the exterior of the building and not to terminate within 3 feet of an opening.

11. Lighting & Ventilation:

Lighting and ventilation are required for any finished portion of the basement. Contact your Building Department for specific requirements.

The Building Department staff can help you determine what is necessary to meet minimum safety requirements.

This handout was developed by the Colorado Chapter of the International Code Council as a basic plan submittal under the 2009 International Residential Code. It is not intended to cover all circumstances. Check with your Department of Building Safety for additional requirements.



Building Division

Community Development PHONE: 303.438.6370
1 DesCombes Drive FAX: 303.438.6207
Broomfield, CO 80020 www.broomfield.org

Single Family Residential Basement Finish

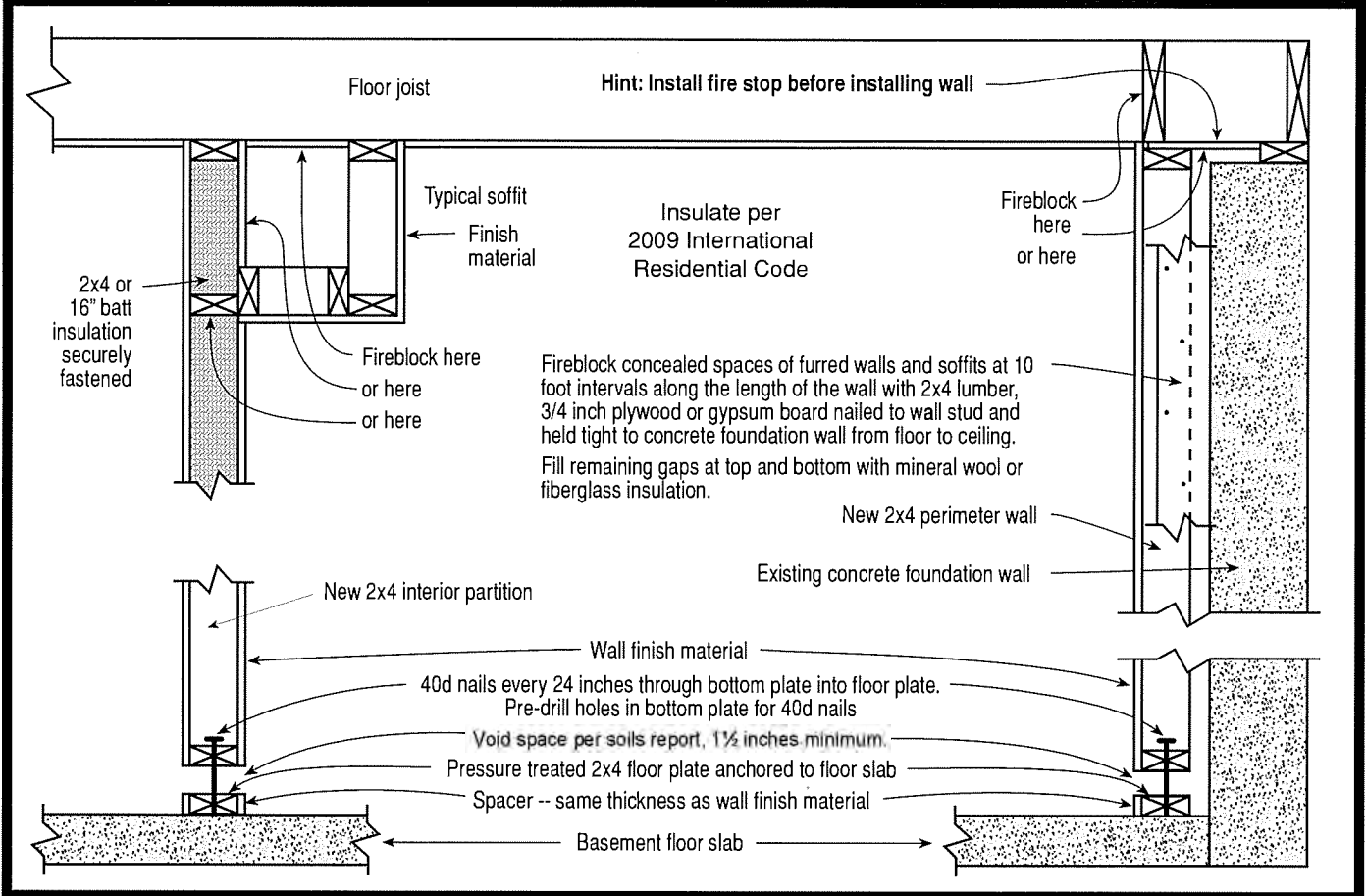

Emergency Escape And Rescue window wells must provide a minimum area of 9 square feet with a minimum dimension of 36 inches and shall enable the window to open fully. If the depth of the window well exceeds 44 inches, a permanently affixed ladder must be provided. The ladder must not interfere with the operation of the window.

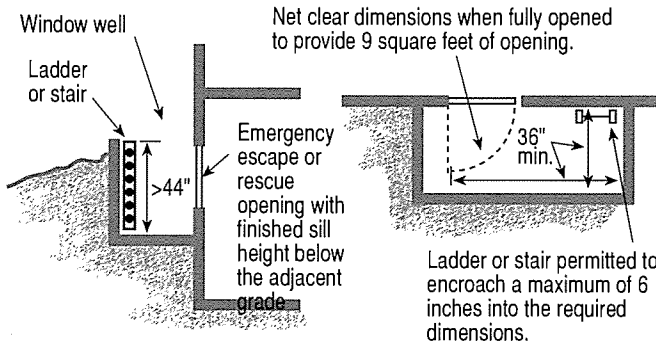

Emergency Escape And Rescue Windows must meet the following criteria:

- A minimum total openable area of not less than 5.7 square feet
- A minimum clear openable height of not less than 24 inches
- A minimum clear openable width of not less than 20 inches.
- A finished sill height of not more than 44 inches above the floor and the window should be openable from the inside with normal operation and without the use of tools, keys or effort.

Examples of Complying Height & Width Combinations

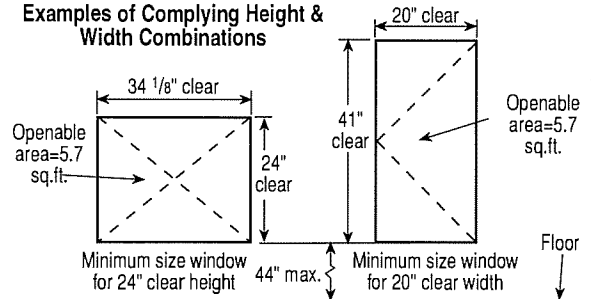

This handout was developed by the Colorado Chapter of the International Code Council as a basic plan submittal under the 2009 International Residential Code. It is not intended to cover all circumstances. Check with your Department of Building Safety for additional requirements.



Building Division

Community Development PHONE: 303.438.6370
 1 DesCombes Drive FAX: 303.438.6207
 Broomfield, CO 80020 www.broomfield.org



COMMUNITY DEVELOPMENT

One DesCombes Drive • Broomfield, CO 80020

SHEET NO. 1 OF 1

JOB NO.

BY MS

DATE 12.15.05 TIME

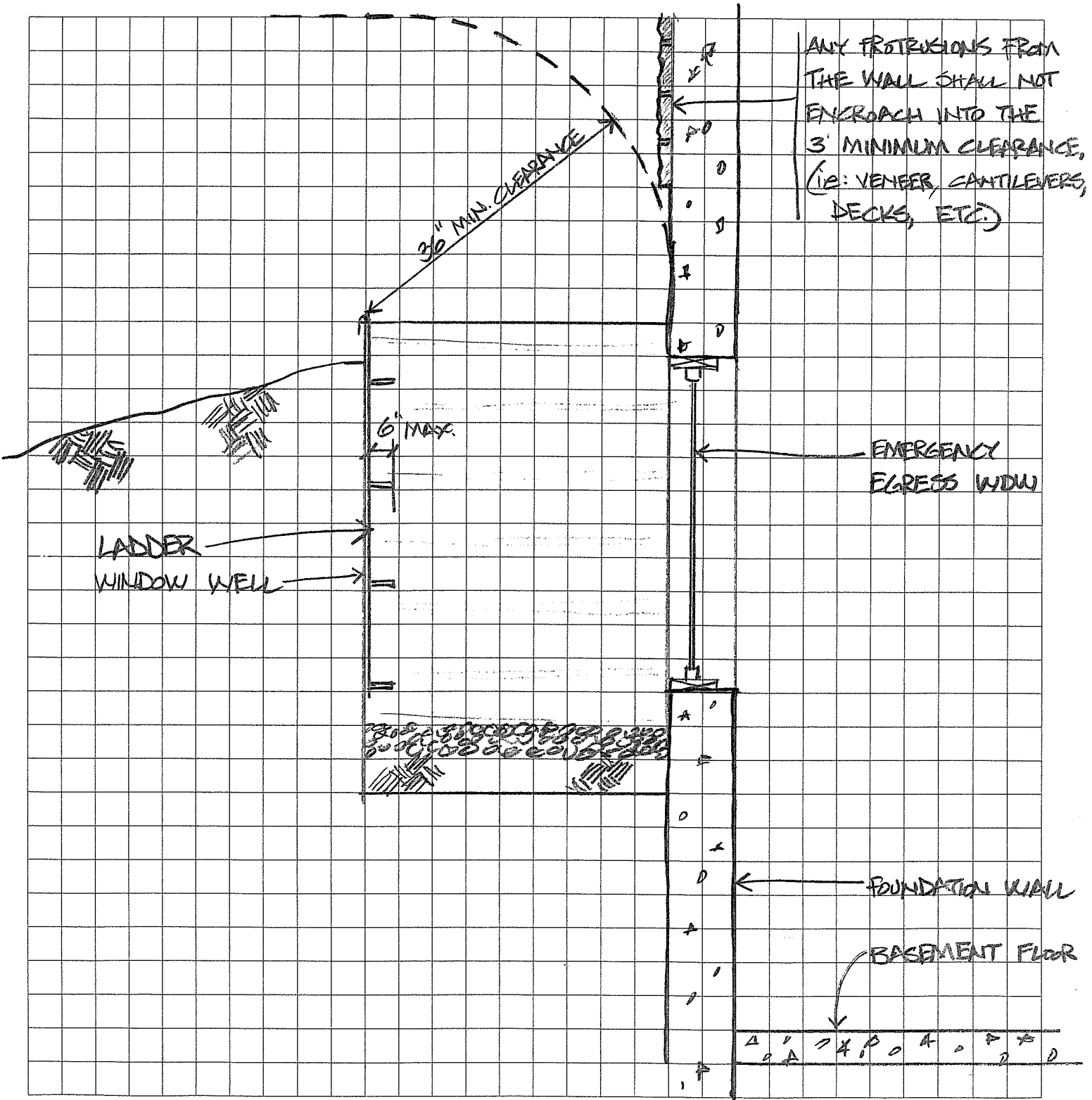

R305.1.1 Basements. Portions of *basements* that do not contain *habitable space*, hallways, bathrooms, toilet rooms and laundry rooms shall have a ceiling height of not less than 6 feet 8 inches (2032 mm).

Exception: Beams, girders, ducts or other obstructions may project to within 6 feet 4 inches (1931 mm) of the finished floor.

**SECTION R306
SANITATION**

R306.1 Toilet facilities. Every *dwelling* unit shall be provided with a water closet, lavatory, and a bathtub or shower.

R306.2 Kitchen. Each *dwelling* unit shall be provided with a kitchen area and every kitchen area shall be provided with a sink.

R306.3 Sewage disposal. All plumbing fixtures shall be connected to a sanitary sewer or to an *approved* private sewage disposal system.

R306.4 Water supply to fixtures. All plumbing fixtures shall be connected to an *approved* water supply. Kitchen sinks, lavatories, bathtubs, showers, bidets, laundry tubs and washing machine outlets shall be provided with hot and cold water.

**SECTION R307
TOILET, BATH AND SHOWER SPACES**

R307.1 Space required. Fixtures shall be spaced in accordance with Figure R307.1, and in accordance with the requirements of Section P2705.1.

R307.2 Bathtub and shower spaces. Bathtub and shower floors and walls above bathtubs with installed shower heads and in shower compartments shall be finished with a nonabsorbent surface. Such wall surfaces shall extend to a height of not less than 6 feet (1829 mm) above the floor.

**SECTION R308
GLAZING**

R308.1 Identification. Except as indicated in Section R308.1.1 each pane of glazing installed in hazardous locations as defined in Section R308.4 shall be provided with a manufacturer's designation specifying who applied the designation, designating the type of glass and the safety glazing standard with which it complies, which is visible in the final installation. The designation shall be acid etched, sandblasted, ceramic-fired, laser etched, embossed, or be of a type which once applied cannot be removed without being destroyed. A *label* shall be permitted in lieu of the manufacturer's designation.

Exceptions:

1. For other than tempered glass, manufacturer's designations are not required provided the *building official*

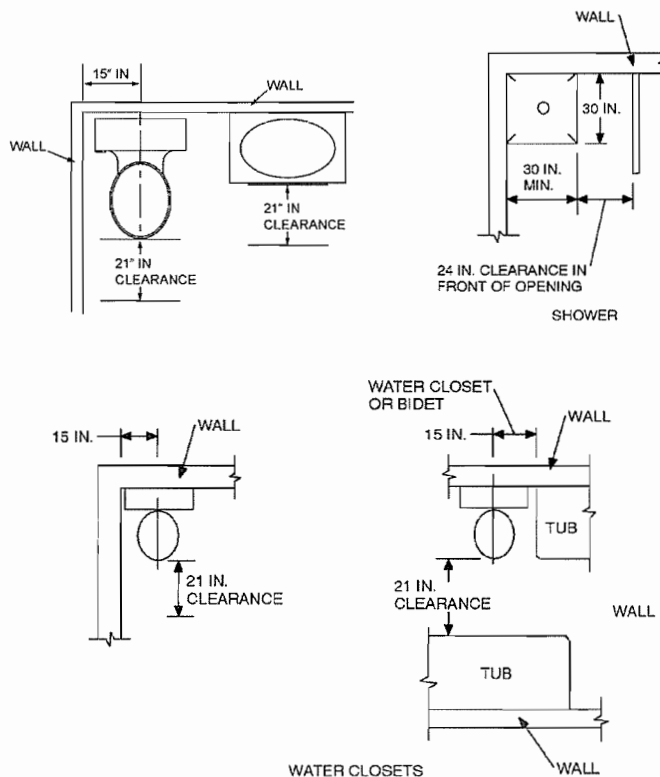

For SI: 1 inch = 25.4 mm.

**FIGURE R307.1
MINIMUM FIXTURE CLEARANCES**

- (2) Supply voltage, number of phases, frequency, and full-load current for each incoming supply circuit.
- (3) Industrial control panels supplied by more than one power source such that more than one disconnecting means is required to disconnect all power within the control panel shall be marked to indicate that more than one disconnecting means is required to de-energize the equipment.
- (4) Short-circuit current rating of the industrial control panel based on one of the following:
 - a. Short-circuit current rating of a listed and labeled assembly
 - b. Short-circuit current rating established utilizing an approved method

Informational Note: UL 508A-2001, *Standard for Industrial Control Panels*, Supplement SB, is an example of an approved method.

Exception to (4): Short-circuit current rating markings are not required for industrial control panels containing only control circuit components.

- (5) If the industrial control panel is intended as service equipment, it shall be marked to identify it as being suitable for use as service equipment.
- (6) Electrical wiring diagram or the identification number of a separate electrical wiring diagram or a designation referenced in a separate wiring diagram.
- (7) An enclosure type number shall be marked on the industrial control panel enclosure.

ARTICLE 410

Luminaires, Lampholders, and Lamps

I. General

410.1 Scope. This article covers luminaires, portable luminaires, lampholders, pendants, incandescent filament lamps, arc lamps, electric-discharge lamps, decorative lighting products, lighting accessories for temporary seasonal and holiday use, portable flexible lighting products, and the wiring and equipment forming part of such products and lighting installations.

410.2 Definitions.

Closet Storage Space. The volume bounded by the sides and back closet walls and planes extending from the closet floor vertically to a height of 1.8 m (6 ft) or to the highest clothes-hanging rod and parallel to the walls at a horizontal distance of 600 mm (24 in.) from the sides and back of the closet walls, respectively, and continuing vertically to the

closet ceiling parallel to the walls at a horizontal distance of 300 mm (12 in.) or the width of the shelf, whichever is greater; for a closet that permits access to both sides of a hanging rod, this space includes the volume below the highest rod extending 300 mm (12 in.) on either side of the rod on a plane horizontal to the floor extending the entire length of the rod. See Figure 410.2.

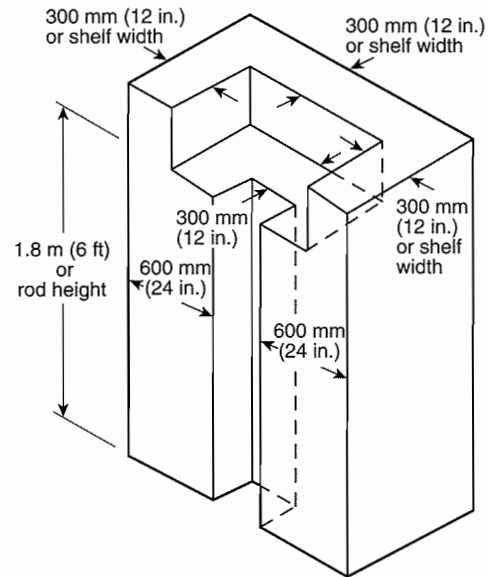

Figure 410.2 Closet Storage Space.

Lighting Track. A manufactured assembly designed to support and energize luminaires that are capable of being readily repositioned on the track. Its length can be altered by the addition or subtraction of sections of track.

410.5 Live Parts. Luminaires, portable luminaires, lampholders, and lamps shall have no live parts normally exposed to contact. Exposed accessible terminals in lampholders and switches shall not be installed in metal luminaire canopies or in open bases of portable table or floor luminaires.

Exception: Cleat-type lampholders located at least 2.5 m (8 ft) above the floor shall be permitted to have exposed terminals.

410.6 Listing Required. All luminaires and lampholders shall be listed.

410.8 Inspection. Luminaires shall be installed such that the connections between the luminaire conductors and the circuit conductors can be inspected without requiring the disconnection of any part of the wiring unless the luminaires are connected by attachment plugs and receptacles.

II. Luminaire Locations

410.10 Luminaires in Specific Locations.

(A) Wet and Damp Locations. Luminaires installed in wet or damp locations shall be installed such that water cannot enter or accumulate in wiring compartments, lampholders, or other electrical parts. All luminaires installed in wet locations shall be marked, "Suitable for Wet Locations." All luminaires installed in damp locations shall be marked "Suitable for Wet Locations" or "Suitable for Damp Locations."

(B) Corrosive Locations. Luminaires installed in corrosive locations shall be of a type suitable for such locations.

(C) In Ducts or Hoods. Luminaires shall be permitted to be installed in commercial cooking hoods where all of the following conditions are met:

- (1) The luminaire shall be identified for use within commercial cooking hoods and installed such that the temperature limits of the materials used are not exceeded.
- (2) The luminaire shall be constructed so that all exhaust vapors, grease, oil, or cooking vapors are excluded from the lamp and wiring compartment. Diffusers shall be resistant to thermal shock.
- (3) Parts of the luminaire exposed within the hood shall be corrosion resistant or protected against corrosion, and the surface shall be smooth so as not to collect deposits and to facilitate cleaning.
- (4) Wiring methods and materials supplying the luminaire(s) shall not be exposed within the cooking hood.

Informational Note: See 110.11 for conductors and equipment exposed to deteriorating agents.

(D) Bathtub and Shower Areas. No parts of cord-connected luminaires, chain-, cable-, or cord-suspended luminaires, lighting track, pendants, or ceiling-suspended (paddle) fans shall be located within a zone measured 900 mm (3 ft) horizontally and 2.5 m (8 ft) vertically from the top of the bathtub rim or shower stall threshold. This zone is all encompassing and includes the space directly over the tub or shower stall. Luminaires located within the actual outside dimension of the bathtub or shower to a height of 2.5 m (8 ft) vertically from the top of the bathtub rim or shower threshold shall be marked for damp locations, or marked for wet locations where subject to shower spray.

(E) Luminaires in Indoor Sports, Mixed-Use, and All-Purpose Facilities. Luminaires subject to physical damage, using a mercury vapor or metal halide lamp, installed in playing and spectator seating areas of indoor sports, mixed-use, or all-purpose facilities shall be of the type that protects the lamp with a glass or plastic lens. Such luminaires shall be permitted to have an additional guard.

410.11 Luminaires Near Combustible Material. Luminaires shall be constructed, installed, or equipped with shades or guards so that combustible material is not subjected to temperatures in excess of 90°C (194°F).

410.12 Luminaires over Combustible Material. Lampholders installed over highly combustible material shall be of the unswitched type. Unless an individual switch is provided for each luminaire, lampholders shall be located at least 2.5 m (8 ft) above the floor or shall be located or guarded so that the lamps cannot be readily removed or damaged.

410.14 Luminaires in Show Windows. Chain-supported luminaires used in a show window shall be permitted to be externally wired. No other externally wired luminaires shall be used.

410.16 Luminaires in Clothes Closets.

(A) Luminaire Types Permitted. Only luminaires of the following types shall be permitted in a closet:

- (1) Surface-mounted or recessed incandescent or LED luminaires with completely enclosed light sources
- (2) Surface-mounted or recessed fluorescent luminaires
- (3) Surface-mounted fluorescent or LED luminaires identified as suitable for installation within the closet storage space

(B) Luminaire Types Not Permitted. Incandescent luminaires with open or partially enclosed lamps and pendant luminaires or lampholders shall not be permitted.

(C) Location. The minimum clearance between luminaires installed in clothes closets and the nearest point of a closet storage space shall be as follows:

- (1) 300 mm (12 in.) for surface-mounted incandescent or LED luminaires with a completely enclosed light source installed on the wall above the door or on the ceiling.
- (2) 150 mm (6 in.) for surface-mounted fluorescent luminaires installed on the wall above the door or on the ceiling.
- (3) 150 mm (6 in.) for recessed incandescent or LED luminaires with a completely enclosed light source installed in the wall or the ceiling.
- (4) 150 mm (6 in.) for recessed fluorescent luminaires installed in the wall or the ceiling.
- (5) Surface-mounted fluorescent or LED luminaires shall be permitted to be installed within the closet storage space where identified for this use.

410.18 Space for Cove Lighting. Coves shall have adequate space and shall be located so that lamps and equipment can be properly installed and maintained.